

Nov. 1, 2007

WIESE INDUSTRIES

APPLICATION BULLETIN

Wiese Industries is issuing a reminder to check the shanks on DMI/CNH rippers/subsoilers for excessive wear that may limit the features and benefits of Wiese replacement points.

The OEM points for these machines used an open bottom mounting boot. This design exposes the bottom of the shank to wear that may allow the replacement point to rotate up and down.

This situation can cause difficulty in penetration, increase horsepower requirements, and result in premature point failure.

To ensure proper fit of Wiese replacement points, refer to Page 2 for approximate original shank dimensions. The shanks may require repair to return the worn areas back to the same size as a new shank. Replacement shanks may have to be installed if repair is not feasible.

Thank you for using Wiese replacement points.

	1-1/4" shank	1-1/2" shank
2" width	41BDMI211442	41BDMI211242
7" width	41BDMI711442	41BDMI711242
10" width	N/A	41BDMI011242

We apologize for any inconvenience in application.

Please contact customer service at 1-800-568-4391 for assistance.

Wiese Industries cannot recommend any welding procedures due to liability. All repair procedures should be done by a qualified repair service.

All dimensions shown are approximate and should be used for reference only.

DMI 1-1/4" Subsoiler Shank

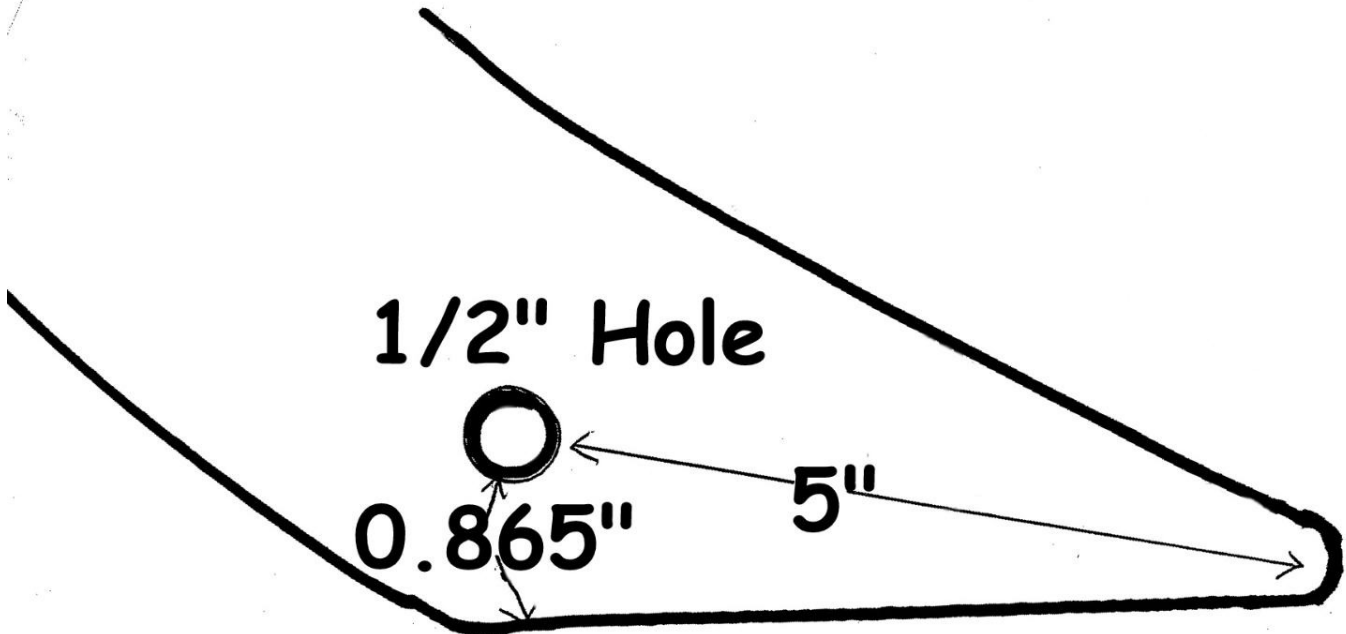

DMI 1-1/2" Subsoiler Shank

1/2" Mounting Hole

